

XpressChef®

Project #: _____

Item #: _____



High Speed Combination Oven XpressChef® 4i (MXP) Series

Superior cooking results **FAST!**

- 2000W impingement enhances browning. Easily adjustable 0-100% fan speed
- 95° - 270°C (200° - 520°F) convection temperature range
- 3000W Infra-red radiant enhances toasting, browning, and crisping
- 2000 - 2200W dual side antenna feed microwave system heats quickly reduces cooking time

Simplifies cooking

- True-Touch™ HD Touchscreen. Fully customizable 178mm (7") smartphone-like display
- Catalytic converter built-in for ventless operation
- Large interior easily accommodates a 35cm (14") pizza

Multi-language universal operation, with programming flexibility

- Touchscreen and programming software supports 25 languages
- Image-based menu selection eliminates language and literacy barriers
- Connectivity Standard: WiFi, Ethernet, and Smart USB standard

Cuts Costs

- Uses less energy than a conventional oven
- Eliminates need for pre-cooking and holding
- Uses standard metal trays, pans and screens

Safe operation and simple cleaning

- Inner door drops down below cooking surface for safe removal of food from cavity
- Porcelain IR element cover enhances operator safety and simplifies maintenance
- Infra-red element tilts-up for cleaning
- Non-stick oven liners preinstalled for easy cleaning***
- Two removable, cleanable, and reusable air filters protect oven components

Included Accessories:

- Oven paddle (PA10)
- Non-stick liners: Sides only (TL10T2)
- Non-stick liners: Full set- sides, door, base, back (TL10***)

Optional Accessories

- Panini grill plate (GR10)
- Panini Press (PRS10)
- Pizza Stone (ST10X)
- Square metal pan (SQ10)
- 4" (102mm) Leg kit (LG10)
- Non-stick baskets (NB10, OB10, TB10/S, SB10/S, MB10/S)
- Oven Cleaner and Shield Protectant (CL10*, SH10*, CL10W**, PR10W**)

XpressChef® 4i (MXP) Series | Heavy Volume This category of high speed oven is ideal for...

Applications

- Theatres
- Convenience Stores
- Satellite Locations
- Healthcare
- Stadiums
- Pizzerias
- Hotel Room Service
- Campus Dining
- Snack Bars

Through put potential (per hour)

Food item	QTY per hour
30cm (12") frozen pizza	21
15cm (6") toasted sandwiches	80+
Grilled fresh Salmon	28
0.45kg (1 lb.) fresh shrimp	55
Toasted Bagel	120
Chicken wings	24
Quesadillas	70

Location of Oven(s):

- Kitchen countertop, single or stacked
- Kitchen shelf
- Equipment stand

All ACP, Inc. commercial ovens are supported by our Culinary Center. Do not hesitate to contact us for any questions regarding food preparation, menu development and cooking times: testkitchen@acpsolutions.com



Patents Pending

Service

All products are backed by the ACP, Inc. 24/7 ComServ Support Center



Warranty

Warranty Certificate for this product can be found on the ACP, Inc. website at www.acpsolutions.com/warranty



Safety and Sanitation

This ACP, Inc. product meets and exceeds safety and sanitation standards set for commercial microwave ovens by UL, ETL, NSF, CSA, FDA, ETL EU and CE



*Only shipped in U.S.A.

** Only shipped in Europe

***Select models only

225 49th Ave. Dr. SW Cedar Rapids, IA 52404 U.S.A.

800-233-2366

319-368-8120

Fax: 319-368-8198

www.acpsolutions.com



© 2023 ACP, Inc.
Cedar Rapids, Iowa 52404

AIA File #:

Specification #:

XpressChef® 4i (MXP) Series | High Speed Combination Oven

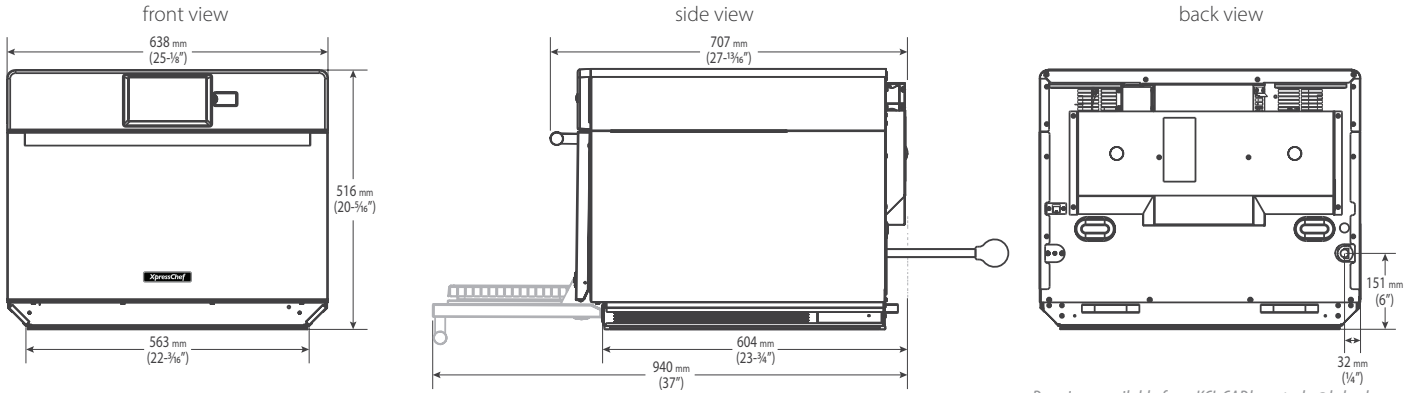

Drawings available from KCL CADlog - techs@kclcad.com

Dimensions			
Exterior	H 516 (20 5/16")	W 638 (25 1/8")	D† 707 (27 13/16")
Cavity	H 254 (10")	W 406 (16")	D 381 (15")
Usable Cavity Space	39 liter (1.38 cubic ft.)		
Door Depth	940 (37"), drop down door		
Installation Clearances	Top: 51 (2")	Sides: 25 (1")	Back: None
Shipping Carton	H 622 (24 1/2")	W 879 (34 5/8")	D 828 (32 5/8")
Weight			
Product Weight	68 kg (150 lbs.)		
Ship weight (approx.)	79 kg (175 lbs.)		

Features	
Configuration	Countertop
Stackable	Yes
Display	178 (7") Capacitive Touch, High resolution LCD display
USB Port	Yes
Connectivity	Wifi and Ethernet
Program Menu	Tab & Multi-level menu capability
Menu Capacity	1200+ items
Max. Cooking Time	99:99
Temperature Range	95° - 270°C (200° - 520°F)
Microwave Distribution	Double side oscillating antenna
Fan Speed	0-100%
Power Levels	11
Defrost	Yes, microwave only, power level 2
Time Entry Option	Yes
Stage Cooking	Yes, 4
Catalytic Converter	Yes†
Automatic Voltage Sensor	Yes (North America only)
Air Filter	2 removable, with clean filter reminder
Rack	1 rack position, removable
Door Opening	Pull down, ergonomic handle
Exterior Finish	Stainless steel & Painted Steel
Interior Finish	Stainless steel

ACP, Inc. requires installing a type D circuit breaker for all high-speed oven installations.

Measurements are millimeters. Measurements in () are US Standard

* IEC 60705 Tested

† Includes handle

‡ Catalytic convertor filters grease and odors from the air. This product conforms to the Ventless

Operation Recommendations set forth by NFPA96 using EPA202 test method

EMEA = Europe, the Middle East and Africa; APAC = Asia Pacific and Oceania; LATAM = Latin America

Electrical Configuration

Region	Model#/UPC	Non-Stick Liners Installed	Power Output/Cooking Power				Power Source	Plug Configuration		Cord Length	Frequency	Magnetron
			Power Consumption	Impingement	IR-Radiant	Microwave		Configuration	Frequency			
North America single phase	MXP22TLT 728028377149	Sides	5700 W, 27.4 A	2000 W	3000 W	2200 W*	208-240 V, 60 Hz, 30 A, single phase	NEMA 6-30P	1.5m (5 ft.)	2450MHz	2	
Brazil single phase	MXP22BT 728028422597	Sides	5700 W, 27.4 A	2000 W	3000 W	2200 W*	220V, 60 Hz, 32 A, single phase	IEC 309	2.4 m (8 ft.)	2450MHz	2	
EMEA, APAC, LATAM single phase	MXP5221TLT 728028422580	Full	5800 W, 27.4 A	2000 W	3000 W	2200 W*	230-240 V, 50 Hz, 32 A, single phase	IEC 309	2.4 m (8 ft.)	2450MHz	2	
EMEA, APAC, LATAM multi phase	MXP5223TLT 728028422634	Full	5800 W, 16 A	2000 W	3000 W	2200 W*	400 V, 50 Hz, Wye, 16 A, 3 phase, 5 wire	IEC 309	2.4 m (8 ft.)	2450MHz	2	
Japan single phase	MXP5201JT 728028422603	Sides	5000 W, 27.4 A	2000 W	2900 W	2000 W*	200V, 50 Hz, 30 A, single phase	NEMA L6-30P	1.5 m (5 ft.)	2450MHz	2	
Japan single phase	MXP6201JT 728028422610	Sides	5000 W, 27.4 A	2000 W	2900 W	2000 W*	200V, 60 Hz, 30 A single phase	NEMA L6-30P	1.5 m (5 ft.)	2450MHz	2	
Saudi Arabia single phase	MXP22TLTSA 728028423198	Sides	5700 W, 27.4 A	2000 W	3000 W	2200 W*	220 V, 60 Hz, 30 A, single phase	Direct Wire	1.5m (5 ft.)	2450MHz	2	

ACP INC. 225 49th Ave. Dr. SW, Cedar Rapids, IA 52404 U.S.A.
800-233-2366 • 319-368-8120 • Fax: 319-368-8198
www.acpsolutions.com

Part No. 20271214

Updated 07/10/2023

© 2020 ACP, Inc., Cedar Rapids, Iowa 52404

an Ali Group Company



The Spirit of Excellence

Specification #:

AIA File #: